

# SERVICE MANUAL

## *Hydraulic Motors type MR- series 4* *and MLHR...E*

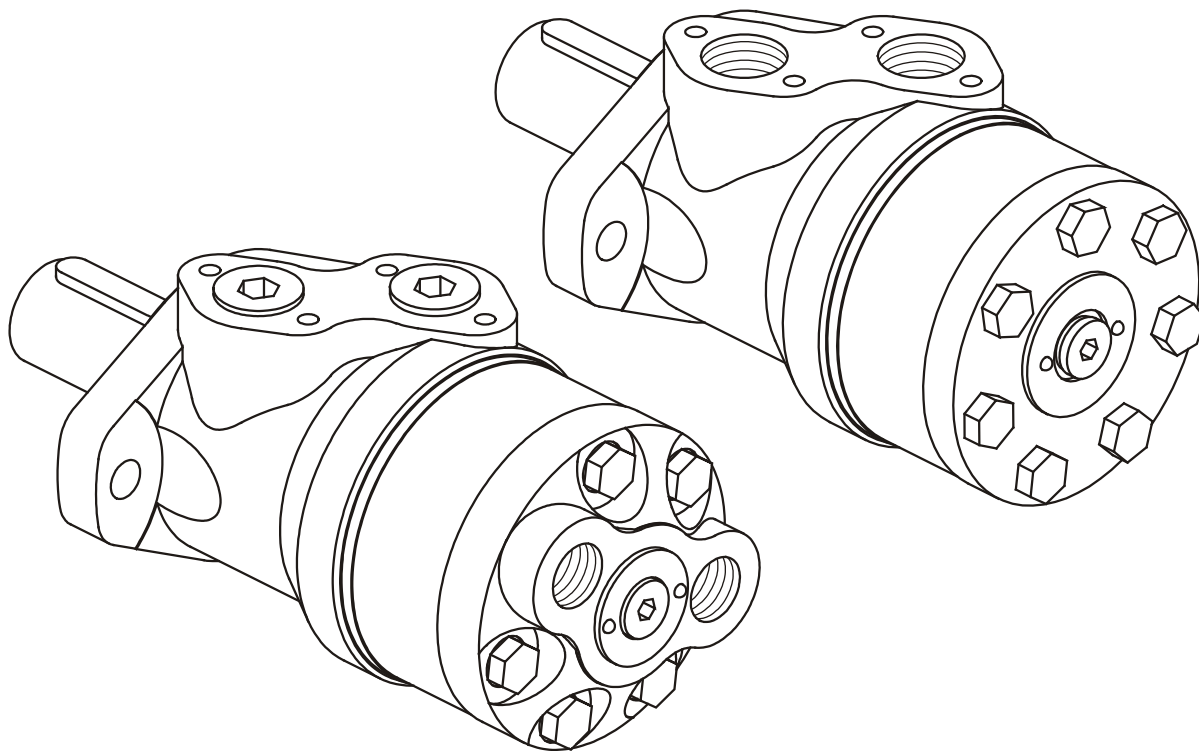

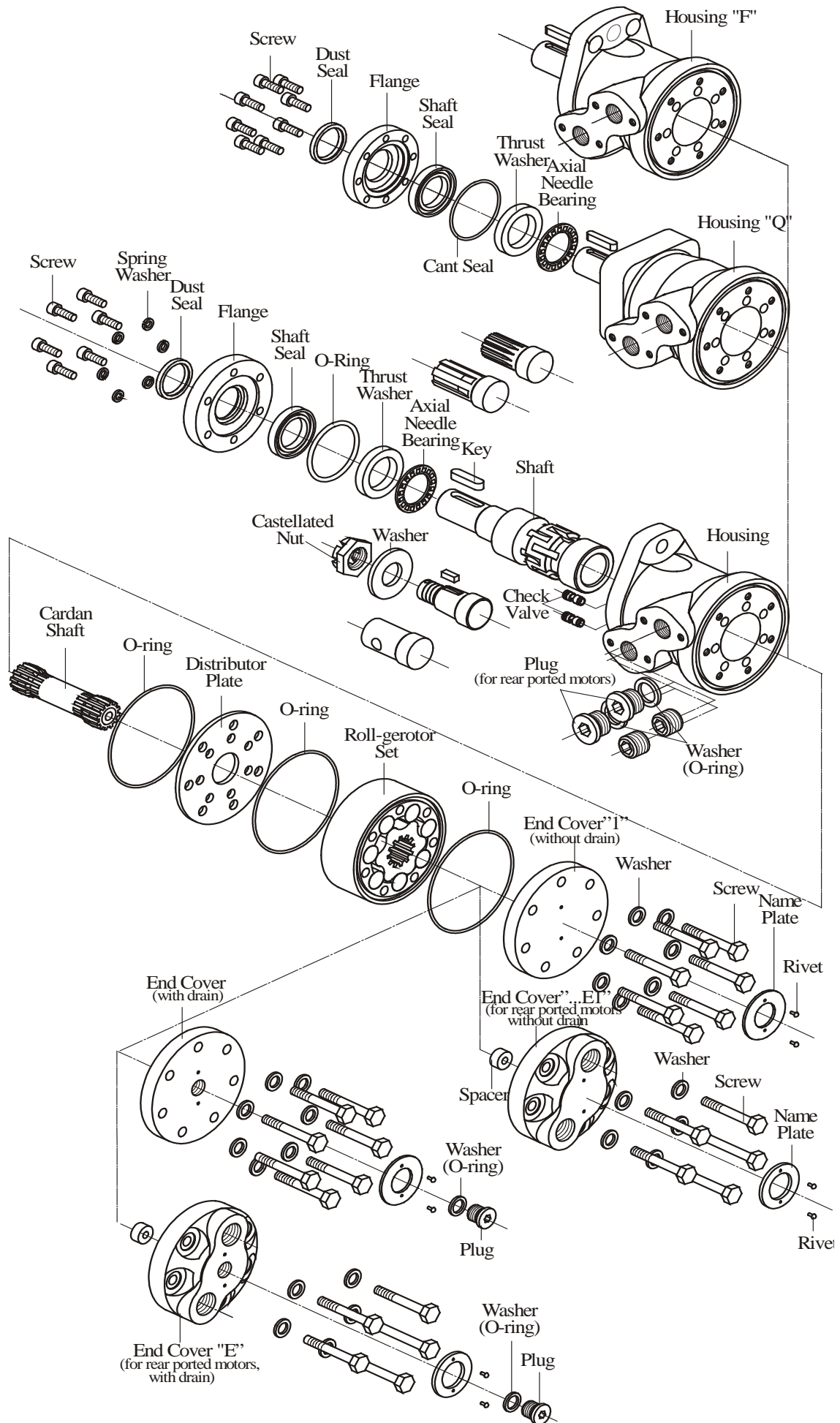

Instructions in this manual are for MR-series 4 and MLHR...E motors.

Cleanliness is extremely important when repairing these motors. Work in clean area!

Before disassembly, drain oil from motor.

Remove castellated nut, washer and key when used. For motors with drain unscrew drain plug and remove washer (O-ring).

Although not all drawings show the motor in disassembly devise (vise), we recommend that you keep motor clamped during disassembly.

1. For rear ported motors only! Unscrew the plugs using S10 Allen head spanner and remove the washers.

2. Place the motor in disassembly devise with output shaft down.

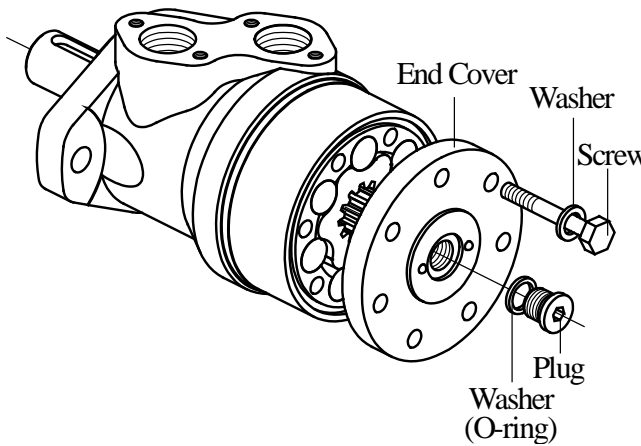

Fig.1

3. Unscrew screws using S13 torque wrench. Remove washers (see Figure 1).

4. Remove end cover.

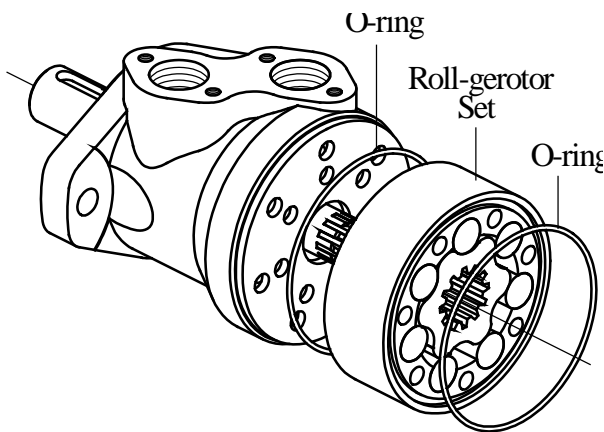

Fig.2

5. Remove the roll-gerotor set carefully to prevent dropping of rollers and rotor from stator. Do not dismount!

Remove O-rings from roll-gerotor set grooves (see Figure 2).

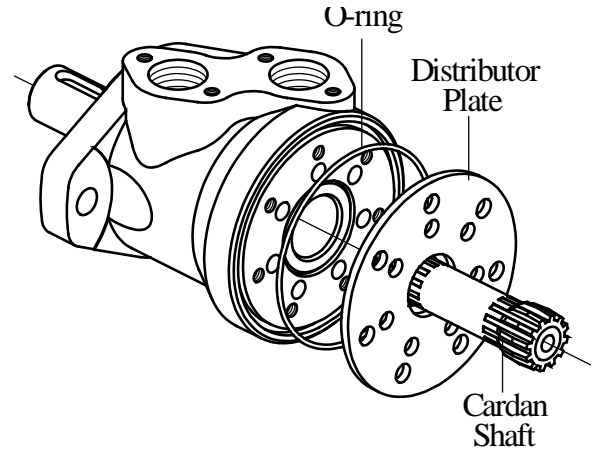

Fig.3

6. Remove cardan shaft (see Figure 3).

7. Remove distributor plate.

8. Remove O-ring from housing.

Reposition motor in disassembly devise with shaft upwards.

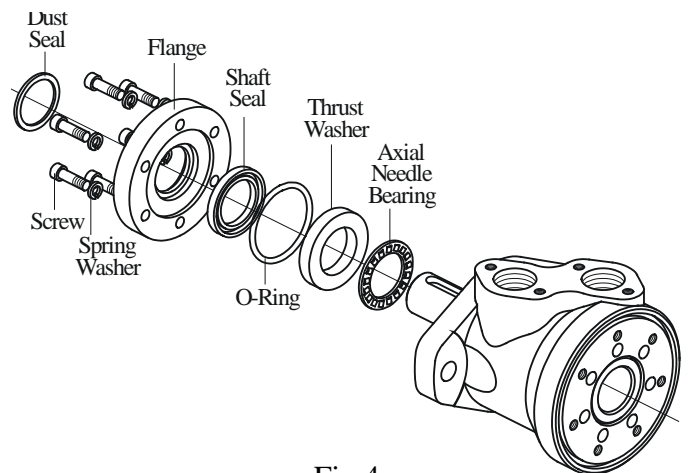

Fig.4

9. Unscrew screws using S6(5) Allen wrench (see Figure 4)

For "Q"-flange only: The screws (8 psc.) are assembled with Loctite to hold them in place. A higher torque is required to break screws loose.

10. Remove flange from housing. Dust seal and Shaft seal will come out with flange.

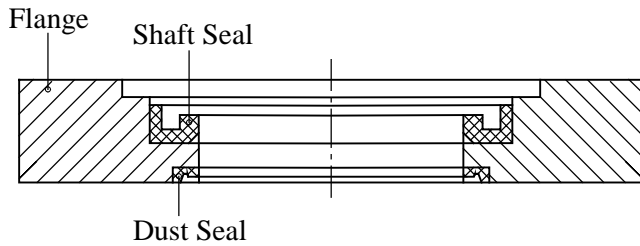

Fig.5

11. Remove with screwdriver Dust seal and Shaft seal from flange (see Figure 5). Work from outer side for both seals.

Note: Some motors may have Quad-ring in place of the Shaft seal.

12. Remove shaft from housing.

13. Remove thrust washer and needle bearing from shaft (see Fig.6).

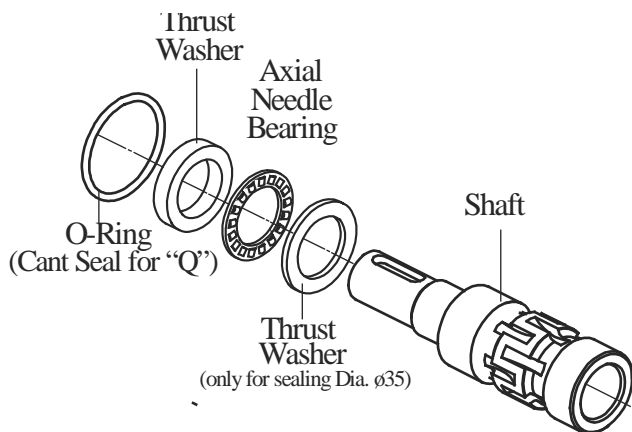

Fig.6

14. Remove O-ring from outer diameter of thrust washer.

Note: It is not necessary to dismount check valves unless leakage occurs around check valve. Replace with new one.

### 1. CLEANING:

Wash all parts (except seals) in a weak solvent on carbon base and then degrease.

### 2. MEASURING AND REPLACEMENT:

Measure all parts and compare actual dimensions with the nominal ones given in the technical documentation. Replace any parts with scratches or burrs that could cause leakage or damage with new ones. Use new seals when reassembling motor.

### 3. LUBRICATION:

Lubricate all seal parts which should be reassembled with light film of petroleum jelly.

### Seal Kits:

SK41 5127 5000 for MR(F)...series 4  
 SK41 5127 5180 for MRQ...series 4  
 SK41 5127 5009 for MR(F)...D-series 4  
 and MR(F)...N...D-series 3  
 SK41 5127 5189 for MRQ...D-series 4  
 and MRQ...N...D-series 3  
 SK41 5127 5018 for MR(F)...Useries 4  
 SK41 5127 5198 for MRQ...Useries 4  
 SK41 5138 4600 for MR(F)...B series 3 (ø35 sealing dia.)

SK41 5122 0001 for MLHR(F)...E;  
 and MLHR(F)...N...D  
 SK41 3131 0009 for MLHR(F)...UE  
 SK41 5131 6900 for MLHR(F)...D (ø35 sealing dia.)  
 SK41 5122 0145 for MLHRQ(M)...E  
 and MLHRQ(M)...N...D  
 SK41 5131 0441 for MLHRQ(M)...UE

1. Lubricate output shaft with hydraulic oil.

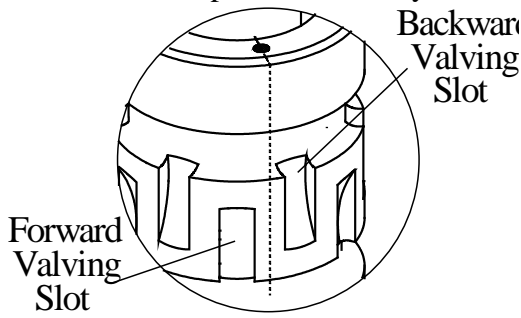

Fig.7

2. On the bottom of the shaft mark a Timing dot placed between forward and backward valving slots as shown on Figure 7.

3. Lubricate lightly all internal housing surfaces with hydraulic oil. Mount shaft in housing.

4. Place the motor in reassembly device with output shaft up.

5. Install needle bearing, then thrust washer on the shaft (see Fig.6).

6. Place lubricated O-ring 48x2 round thrust washer (Cant seal 47,35x1,68x1,68 for "Q"-flange).

7. Place flange on clean soft surface. Lubricate shaft seal and dust seal with light film of clean petroleum jelly (Shell Retinax Grease HDX2).

8. Place shaft seal in Flange and firmly push with Seal driver (see Fig.8).

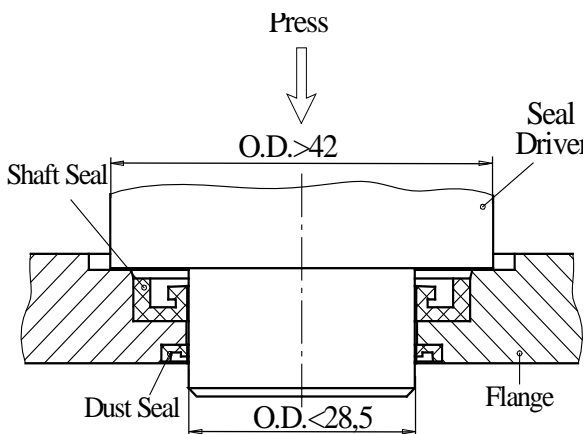

Fig.8

9. Install dust seal in flange. Carefully press dust seal into place.

Lips of shaft seal and dust seal must face outward.

**Important:** Check seal condition after installing in housing. If damaged, cut or improperly installed, replace with new ones.

10. Install the spigot flange incl. assembled seals on shaft. Prevent the seals and shaft against damages.

11. Install in the flange 6 screws with washers and alternately torque them to 6÷8 Nm (10÷12 Nm for "U" versions).

**For MRQ and MLHRQ(M) only:** Before mounting the screws (8 pcs.) apply 2 or 3 drops of LOCTITE 638 at top of thread of each of holes in housing.

12. Reposition motor in reassembly device with shaft down.

13. Lubricate and install O-ring in housing seal groove (see Fig.3).

**Timing Procedure**

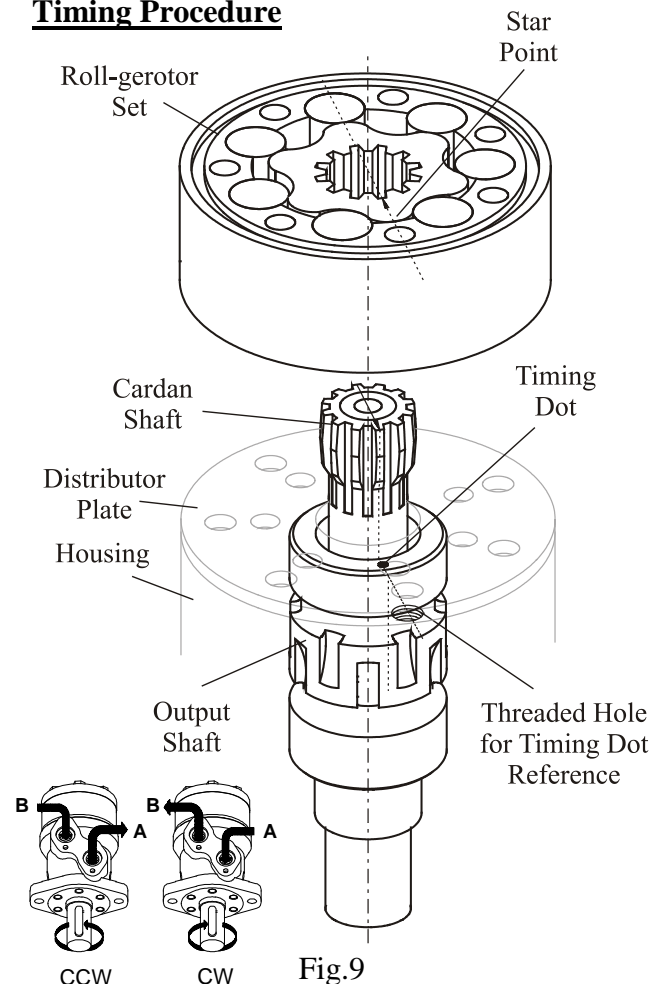

Fig.9

14. Install cardan shaft into splines of output shaft. Mark one cardan shaft tooth and align this tooth with timing dot on shaft.

15. Align shaft timing dot with any housing bolt hole.

16. Install spacer plate on housing. Remember which bolt hole was aligned with the shaft timing dot.

17. Lubricate O-rings (2 pcs.) and place them in seal grooves of both stator sides.

Standard rotation:

18. Place roll-gerotor set on distributor plate positioning any star point over the bolt hole aligned with the timing dot. Stepped bolt holes are facing with smallest diameter to the distributor plate (see Fig.9)

19. Rotate roll-gerotor set to line up with bolt holes.

Reverse Rotation:

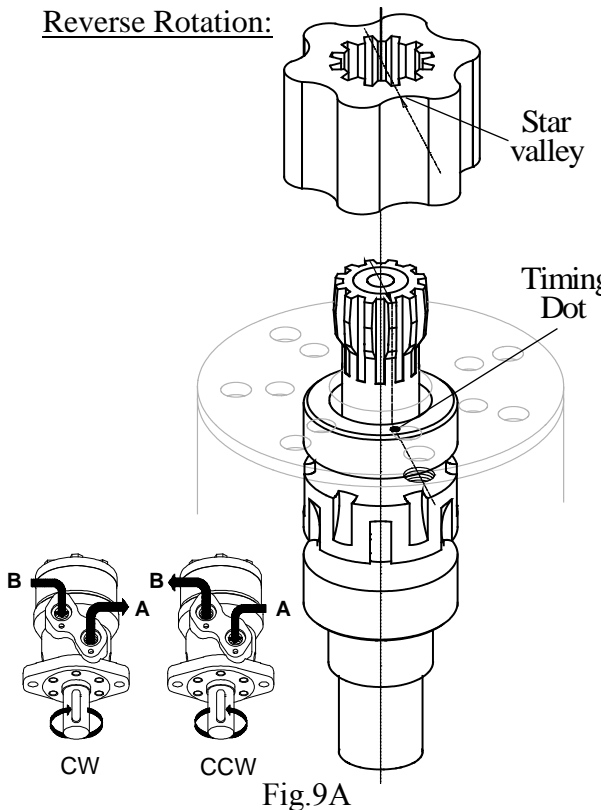

Reverse rotation is obtained by positioning any star valley over the aligned bolt hole (see Fig 9A).

20. Carefully place end cover on roll-gerotor set.

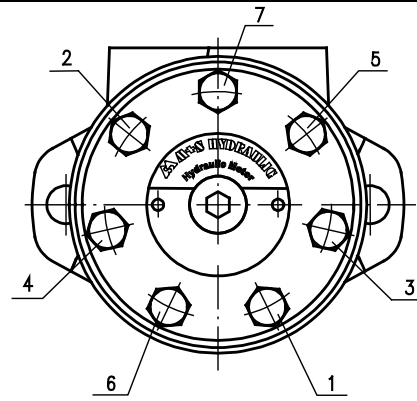

Fig.10

21. Install screws and washers in end cover. Tighten screws with 3÷3,5 daNm torque (4÷4,5 daNm for “U” versions) using a S13 torque wrench in sequence as shown in Fig.10.

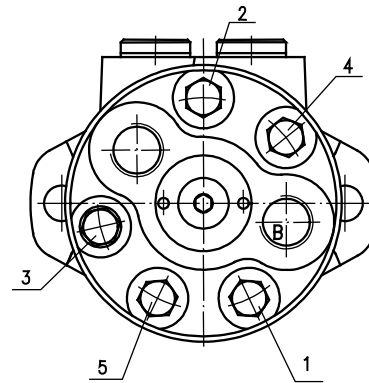

Fig.10A

22. For rear ported motors only: Install washer (O-ring for MLHR...7,8) on plug Tighten plug with S10 Allen wrench with torque 3,0÷3,5 daNm. Make shore that End cover is orientated as shown on Figure 10A!

23. Install washer (O-ring for MLHR...4,5,7,8) on drain plug. Tighten plug with S6 Allen wrench with torque 2,0 ÷ 2,5 daNm

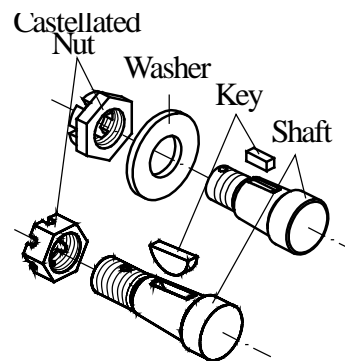

Fig.11

23. Install key in shaft key groove. For cone shafts install washer and screw castellated nut. (see Fig.11).

**Disassembly and reassembly of MR (MLHR)...N... (with Needle Bearings):**

Fig.12

These motors are the same as the standard motors, but have 2 needle bearings. Follow the same disassembly and reassemble procedures as for the standard motor.

Needle bearing HK3516 will come out with Shaft. Knock Needle bearing HK3512 out of housing with plastic hammer and soft bushing.

Assemble the Needle bearing HK3516 in the Housing at a depth of  $9,4 \pm 0,15$  mm from the spigot flange joint. Grease the shaft journals and assemble in the housing. Assemble the Needle bearing HK3512 in the Housing at max. depth of 0,1 mm.

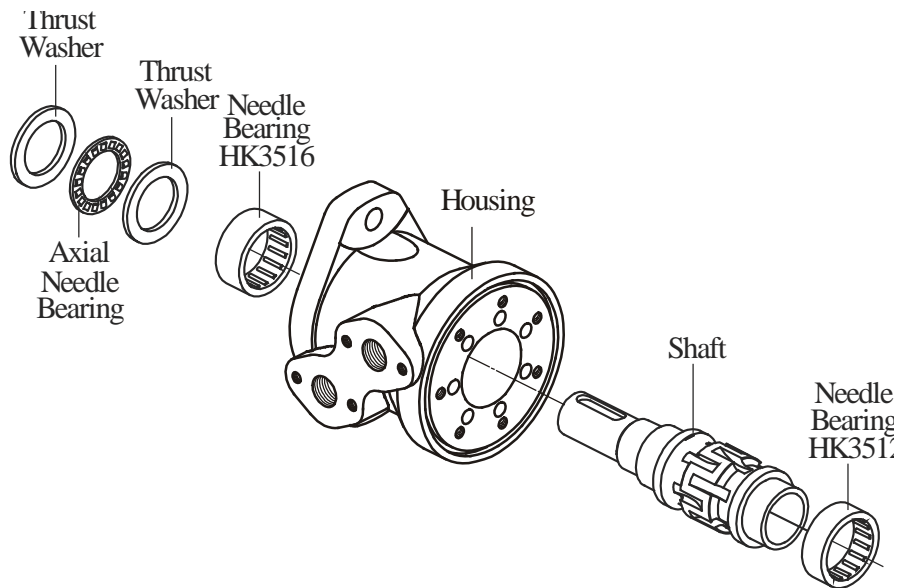
Clearance must be: - between shaft and bearings-  $0,010 \pm 0,003$  mm;

- between bearings and motor housing at diameter  $\varnothing 42$ -  $0,017 \pm 0,003$  mm

**Note:** If it is not necessary, do not disassemble shaft and needle bearings from the motor housing.